

Autonics

**INDUCTIVE PROXIMITY SENSOR
PFI SERIES**

INSTRUCTION MANUAL



Thank you very much for choosing our Autonics product.
Please read the following safety considerations before use.

■ Safety Considerations

※Please observe all safety considerations for safe and proper product operation to avoid hazards.

※⚠ symbol represents caution due to special circumstances in which hazards may occur.

⚠ **Warning** Failure to follow these instructions may result in serious injury or death.

⚠ **Caution** Failure to follow these instructions may result in personal injury or product damage.

⚠ Warning

- Fail-safe device must be installed when using the unit with machinery that may cause serious injury or substantial economic loss. (e.g. nuclear power control, medical equipment, ships, vehicles, railways, aircraft, combustion apparatus, safety equipment, crime/disaster prevention devices, etc.)**
Failure to follow this instruction may result in fire, personal injury, or economic loss.
- Do not disassemble or modify the unit.**
Failure to follow this instruction may result in electric shock or fire.
- Do not connect, repair, or inspect the unit while connected to a power source.**
Failure to follow this instruction may result in electric shock or fire.
- Check 'Connections' before wiring.**
Failure to follow this instruction may result in fire.

⚠ Caution

- Use the unit within the rated specifications.**
Failure to follow this instruction may result in fire or product damage.
- Use dry cloth to clean the unit, and do not use water or organic solvent.**
Failure to follow this instruction may result in electric shock or fire.
- Do not use the unit in the place where flammable/explosive/corrosive gas, humidity, direct sunlight, radiant heat, vibration, impact, or salinity may be present.**
Failure to follow this instruction may result in fire or explosion.
- Do not supply power without load.**
Failure to follow this instruction may result in fire or product damage.

■ Ordering Information

P	FI	25	8	D	N
Item	Shape	Body size	Sensing distance	Power supply	Output
			Number		
			Number		
			FI		
			P		

O	Normally open
C	Normally closed
N	NPN normally open
N2	NPN normally closed
P	PNP normally open
P2	PNP normally closed
D	12-24VDC
A	100-240VAC
Number	Sensing distance(Unit: mm)
Number	A width of the case(Unit: mm)
FI	Flat type(Plastic case)
P	Inductive proximity sensor

■ Dimensions

(Unit: mm)

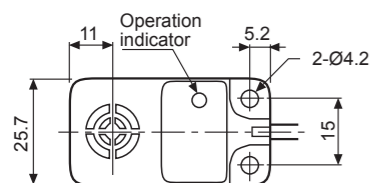

※When installing the product, tighten the screw with a tightening torque of 1.47N·m.

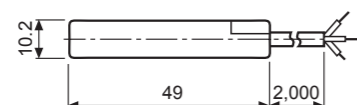

※The above specifications are subject to change and some models may be discontinued without notice.

※Be sure to follow cautions written in the instruction manual and the technical descriptions (catalog, homepage).

■ Specifications

Model	PFI25-8DN, PFI25-8DN2, PFI25-8DP, PFI25-8DP2 PFI25-8AO, PFI25-8AC	
Sensing distance	8mm	
Hysteresis	Max. 10% of sensing distance	
Standard sensing target	25 × 25 × 1mm (Iron)	
Setting distance	0 to 5.6mm	
Power supply (Operating voltage)	12-24VDC (10-30VDC)	100-240VAC ~ 50/60Hz (85-264VAC ~)
Power consumption	Max. 10mA	—
Current consumption	—	Max. 2.5mA
Response frequency*1	200Hz	20Hz
Residual voltage	Max. 1.5V	Max. 10V
Affection by Temp.	When it is 20°C at the rated ambient temperature, it is below 10%.	
Control output	Max. 200mA	5 to 150mA
Insulation resistance	50MΩ Min.(at 500VDC megger)	
Dielectric strength	1,500VAC 50/60Hz for 1 minute	2,500VAC 50/60Hz for 1 minute
Vibration	1mm amplitude at frequency of 10 to 55Hz in each of X, Y, Z directions for 2 hours	
Shock	500m/s ² (approx. 50G) in X, Y, Z directions for 3 times	
Indicator	Operating indicator : Red LED	
Environ-ment	Ambient temperature: -25 to 70°C, Storage: -30 to 80°C	Ambient humidity: 35 to 95%RH, Storage: 35 to 95%RH
Protection circuit	Surge protection circuit, Reverse polarity protection, Overload & Short protection circuit	Surge protection circuit
Protection	IP67(IEC standards)	
Cable*2	Ø4mm, 3 cores, 2m	Ø4mm, 2 cores, 2m
	AWG22, core diameter: 0.08mm, number of cores: 60, insulator diameter: Ø1.25mm	
Material	Case: PPS, General cable(Black): Polyvinyl chloride(PVC)	
Approval	CE	
Weight	Approx. 70g	

- ※1: The response frequency is the average value. The standard sensing target is used and the width is set as 2 times of the standard sensing target, 1/2 of the sensing distance for the distance.
- ※2: Do not pull the cable with a tensile strength of 30N or over. It may result in fire due to the broken wire. When extending wire, use AWG22 cable or over within 200m.
- ※Environment resistance is rated at no freezing or condensation.

■ Control Output Diagram & Load Operating

◎ DC 3 wire type

NPN				
Main circuit	10kΩ	Brown	+V	
		Black	Load	
		Blue	0V	
Sensing target	Presence Nothing	N.O.	N.C.	
Load (Brown-Black)	Operation Return			
Output voltage (Black-Blue)	H L			
Operation indicator (Red LED)	ON OFF			

PNP				
Main circuit	10kΩ	Brown	+V	
		Black	Load	
		Blue	0V	
Sensing target	Presence Nothing	N.O.	N.C.	
Load (Black-Blue)	Operation Return			
Output voltage (Black-Blue)	H L			
Operation indicator (Red LED)	ON OFF			

◎ AC 2 wire type

Main circuit	Z	Brown	Load	
		Blue	100-240VAC 50/60Hz	
Sensing target	Presence Nothing	N.O.	N.C.	
Load	Operation Return			
Operation indicator (Red LED)	ON OFF			

■ Connection of the Power Supply

Be sure to connect the power after connecting the load, because direct connection of the proximity sensor may cause damage to the inner elements of this product.

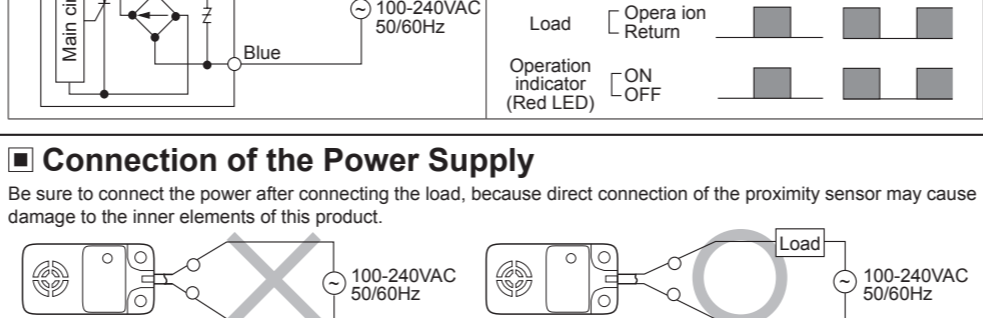

■ Mutual-interference & Influence by Surrounding Metals

◎ Mutual-interference

When several proximity sensors are mounted closely, sensors may cause a malfunction due to mutual interference. Therefore, be sure to provide a minimum distance between the two sensors, as below chart.

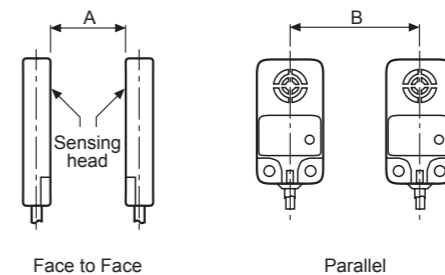

(Unit: mm)

Model	PFI25
Item	
A	100
B	80

◎ Influence by surrounding metals

When sensors are mounted on metallic panel, it may cause malfunction affected by any metallic object except target. Therefore, be sure to provide a minimum as below chart.

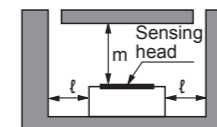

(Unit: mm)

Model	PFI25
Item	
l	5
m	15

■ Setting Distance

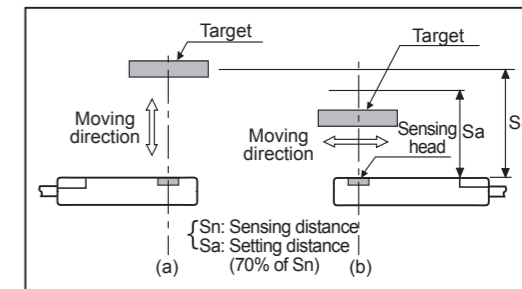

- Sensing distance can be changed by the shape, size or material of the target. Therefore please check the sensing distance like (a), then pass the target within range of setting distance(Sa).
- Setting distance(Sa) = sensing distance(Sn) × 70%
E.g.)PFI25-8DN
Sensing distance(Sa)= 8mm × 0.7 = 5.6mm

■ Caution during Use

- Follow instructions in 'Cautions during Use'. Otherwise, it may cause unexpected accidents.
- 12-24VDC power supply should be insulated and limited voltage/current or Class 2, SELV power supply device.
- Use the product, after 0.8 sec of supplying power.
- Wire as short as possible and keep away from high voltage lines or power lines, to prevent surge and inductive noise.
Do not use near the equipment which generates strong magnetic force or high frequency noise (transceiver, etc.). In case installing the product near the equipment which generates strong surge (motor, welding machine, etc.), use diode or varistor to remove surge.
- This unit may be used in the following environments.
 - ① Indoors (in the environment condition rated in 'Specifications')
 - ② Altitude max. 2,000m
 - ③ Pollution degree 2
 - ④ Installation category II

■ Major Products

- Photoelectric sensors
- Fiber optic sensors
- Door sensors
- Door side sensors
- Area sensors
- Proximity sensors
- Pressure sensors
- Rotary encoders
- Connector/Sockets
- Switching mode power supplies
- Control switches/Lamps/Buzzers
- I/O Terminal Blocks & Cables
- Stepper motors/drivers/motion controllers
- Graphic/Logic panels
- Field network devices
- Laser marking system(Fiber, CO₂, Nd:YAG)
- Laser welding/soldering system
- Temperature controllers
- Temperature/Humidity transducers
- SSR/Power controllers
- Counters
- Timers
- Panel meters
- Tachometer/Pulse(Rate) meters
- Display units
- Sensor controllers